



## AVK RESILIENT SEAT GATE VALVE OS&Y PN16

57/46



Face to face dimension to AS 2638.2  
Flange to AS 4087, drilling to AS 4087 B5 or AS 2129 Table E and raised face



### Use:

- For water, sewage and neutral liquid applications
- Valve designed for use up to 70°C
- Where applicable; for AS 4020 compliance, max temp = 40°C  
Note: Always observe pipe material recommended operating temperatures



### Tests:

- Hydraulic test to AS 2638.2:
  - Seat: 17.6 bar
  - Body: 24 bar
  - Operating torque test

### Optional Extras:

- User specified flange drilling



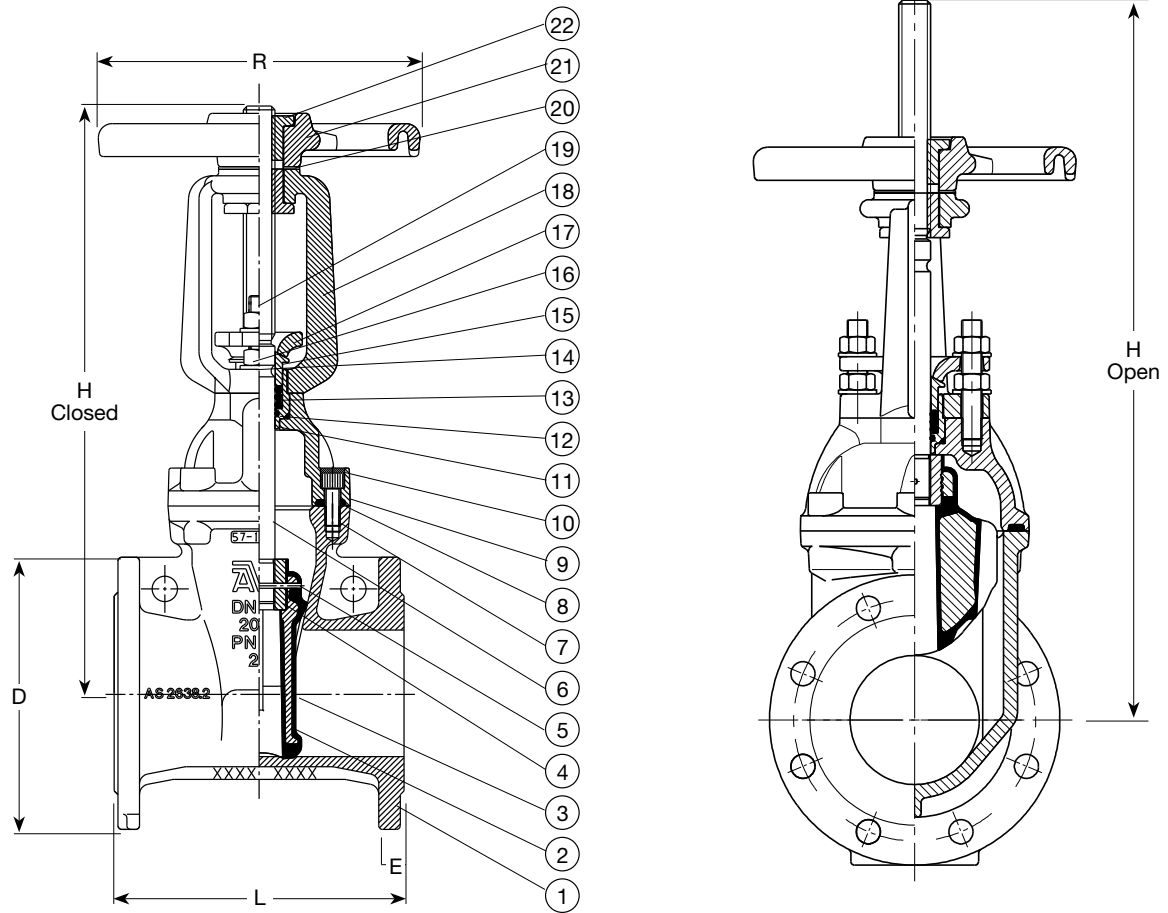

**Component list**

1. Valve body	Ductile Iron, 500-7 to AS 1831	13. O-ring	
2. Wedge body	Ductile Iron, Grade 500-7	14. Washer	Dezincification resistant brass, CZ 132 to AS 2345
3. Wedge	EPDM rubber	15. Gland	Akulon polyamide 6.6
4. Wedge nut	Dezincification resistant brass, CZ 132 to AS 2345	16. Hexagon nut	Dezincification resistant brass, CZ 132 to AS 2345
5. Pin	Stainless Steel 304	17. Gland follower	Ductile Iron 500-7, to AS 1831
6. Stem	Stainless Steel 316	18. Yoke	Ductile Iron 500-7, to AS 1831
7. Bonnet bolt	Grade 8.8 Galvanised, fully encapsulated with hot melt glue	19. Stud bolt	Stainless Steel 316
8. Bonnet gasket	EPDM rubber	20. Washer	Dezincification resistant brass, CZ 132 to AS 2345
9. Valve bonnet	Ductile Iron, 500-7 to AS 1831	21. Handwheel	Ductile Iron, to AS 1831
10. Hot melt		22. Stem nut	Dezincification resistant brass, CZ 132 to AS 2345
11. Gland bushing	Akulon polyamide 6.6		
12. O-ring			

Components can be substituted with equivalent or higher class materials.

**Reference nos. and dimensions**

AVK ref. nos.	DN mm	H open mm	H closed mm	R mm	L mm	D mm	E mm	Holes nos.	Turns to open	Weight kg
57-050-460X43120	50	404	325	229	178	150	19	4	20	24.1
57-065-460X43120	65	423	344	229	190	165	19	4	20	24.2
57-080-460X43120	80	429	350	229	203	185	18	4	20	25
57-100-460X43120	100	524	420	279	229	215	20	4 or 8	21	39
57-150-460X43120	150	736	581	330	267	280	23	8	31	63
57-200-460X43120	200	942	736	356	292	335	23	8	35	97
57-250-460X43120	250	1138	882	457	330	405	24	8 or 12	43	157
57-300-460X43120	300	1317	1009	457	356	455	30	12	44	238

X: Flange drilling:  
 5 = AS 4087 Table B5  
 6 = AS 2129 Table E raised face